

Taal: Meertalig













## Handleiding

Trolley tbv GYSpress  
GY 054233

**MSH equipment**  
Appelmarkt 7  
1681 PE Zwaagdijk-Oost  
Tel: 0228-561100  
Fax: 0228-561112  
Mail: [info@msh-equipment.nl](mailto:info@msh-equipment.nl)

Website: [www.msh-equipment.nl](http://www.msh-equipment.nl)

A	B	C	D	E	F	G	H	I	J
M8x30	M8x12	M8	M6x12	M6	M5x10	M5	M4x6	M4x12	M4
2	18	20	38	38	8	8	30	6	36
									

- Ouvrir la glissière au maximum / Open the slide to its maximum / Öffnen Sie die Schiene bis zum Maximum.
- Déverrouiller la glissière à l'aide du levier en plastique et ouvrir la glissière au maximum / Unlock the slide with the plastic lever and open the slide to its maximum / Entriegeln Sie die Schiene mit dem Plastikhebel und öffnen Sie die Schiene auf das Maximum. (voir photo ci-dessous / see photo below / siehe Foto unten)

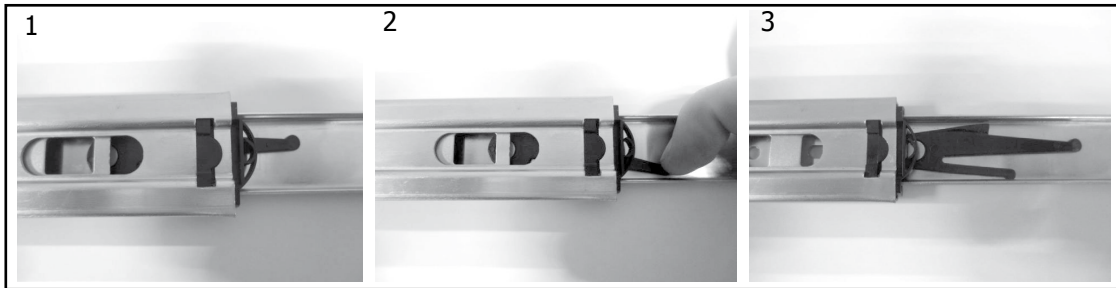

- Présenter la glissière sur le support / Start to place the slide on the support / Legen Sie die Schiene auf das Blech.
- Prévisser la vis I + l'écrou J / Pre-screw the screw I + the nut I / Befestigen Sie die Schiene auf dem Blech mit der Schraube I + der Mutter J.
- Coulisser la glissière et faire correspondre le trou de la glissière avec le trou de fixation / Run the slide and match the slide hole with the fixing hole / Verschieben Sie die Schiene so, dass das Befestigungsloch sich über dem Schienenloch befindet.
- Visser la vis H + l'écrou J / Screw the screw H + the nut J / Schrauben Sie die Schraube H + die Mutter J fest. (voir photos ci-dessous / voir photos ci-dessous / siehe Foto unten)

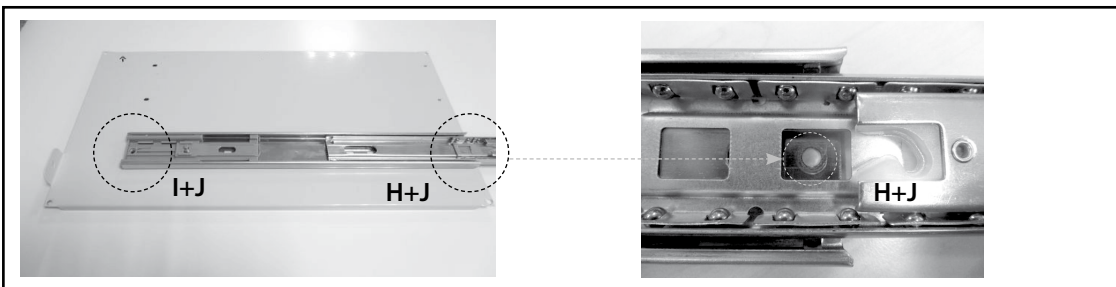

- Finir le vissage de la vis I / Tighten the screw I / Schrauben Sie die Schraube I fest.
- Refermer la glissière / Close the slide / Die Schiene zurückschieben.
- Monter les deux autres glissières de la même façon / Assemble the other two slides the same way / Die beiden anderen Schienen auf die gleiche Weise montieren.
- **1 bis** : Répéter l'opération de montage pour l'autre coté / Repeat the assembly operation for the other side / Wiederholen Sie die Montage auf der anderen Seite.

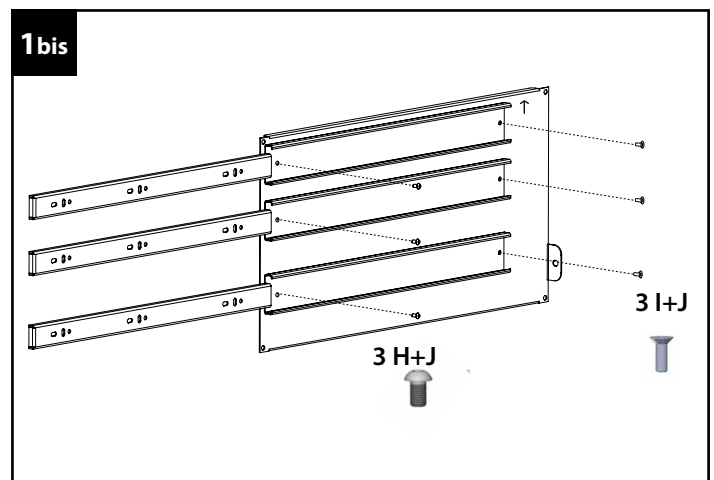
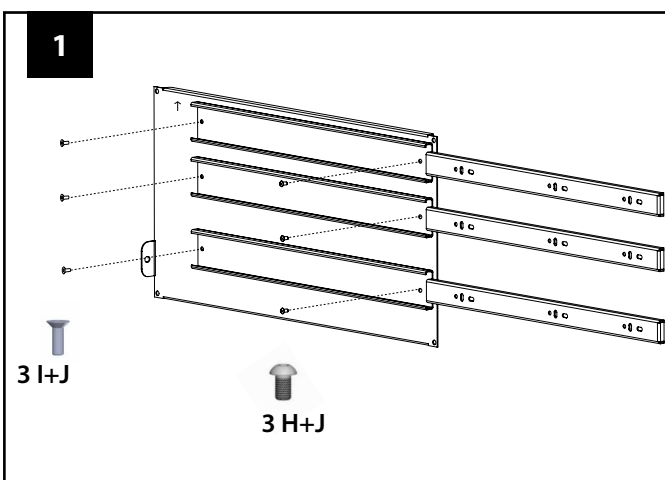

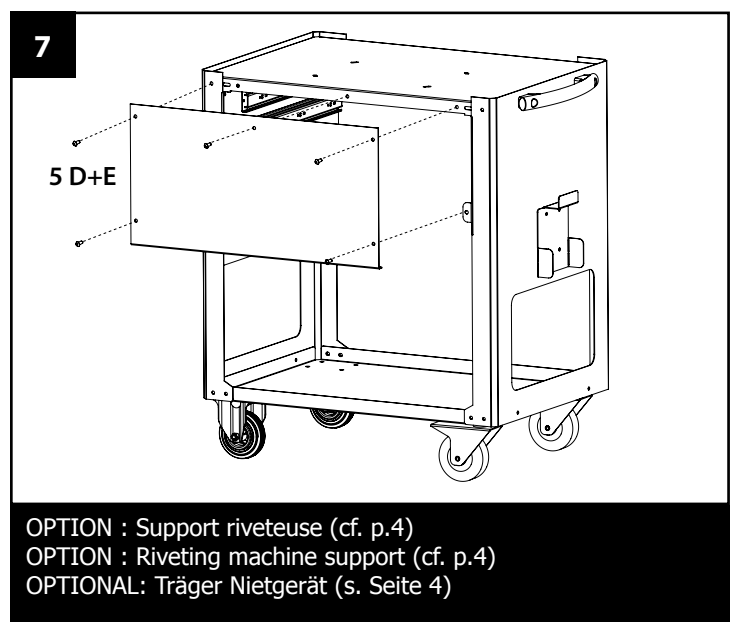
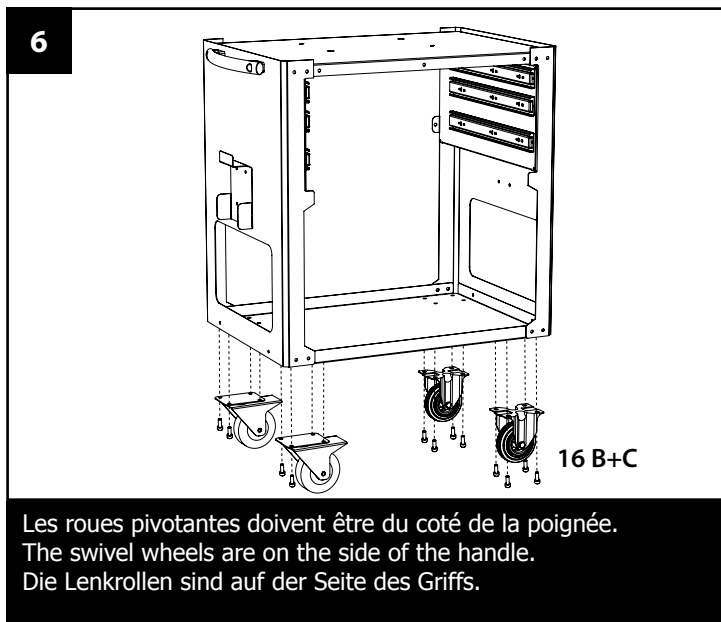
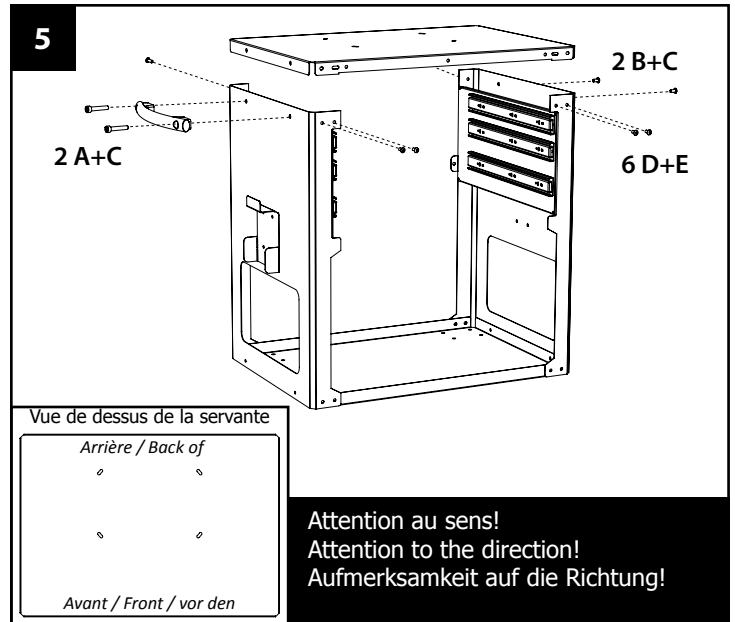
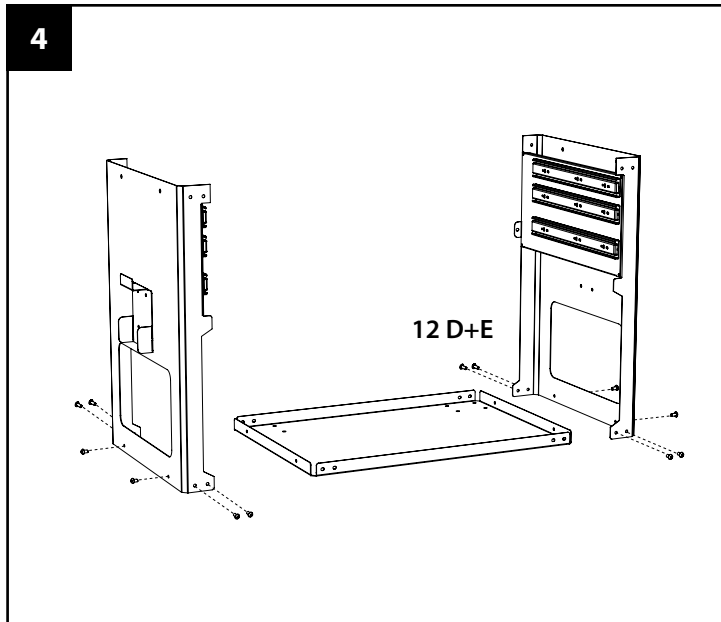
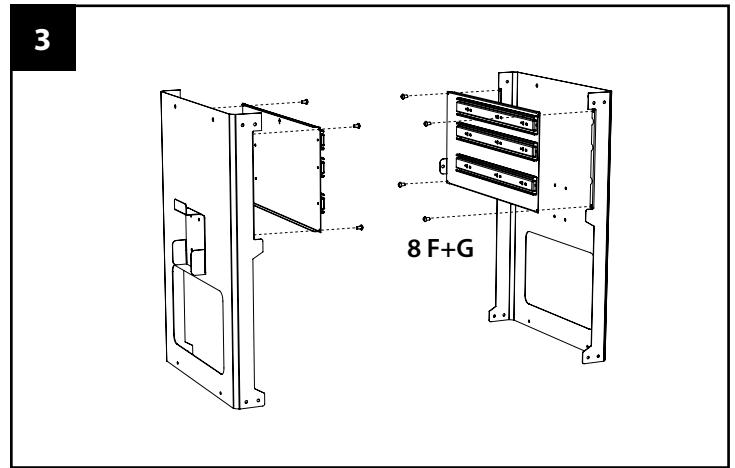
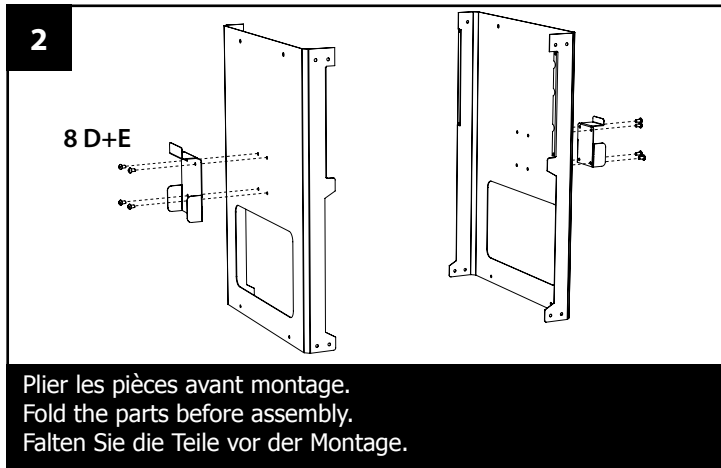

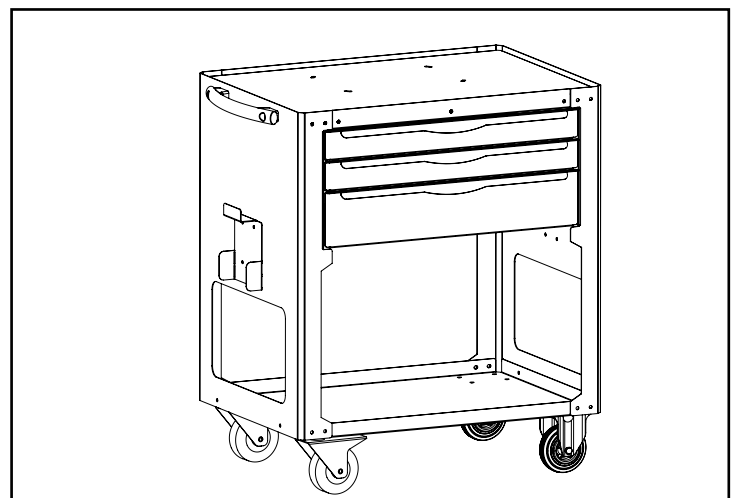
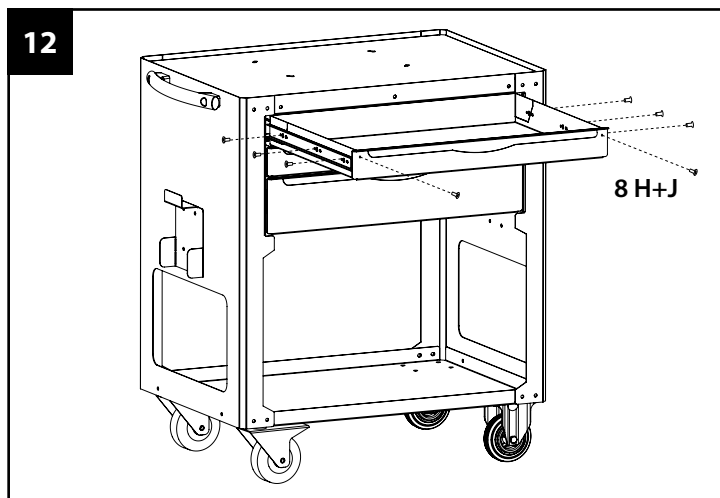
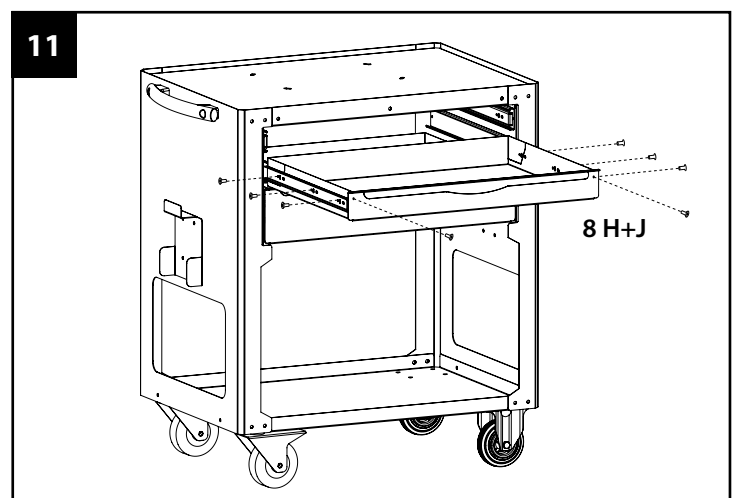
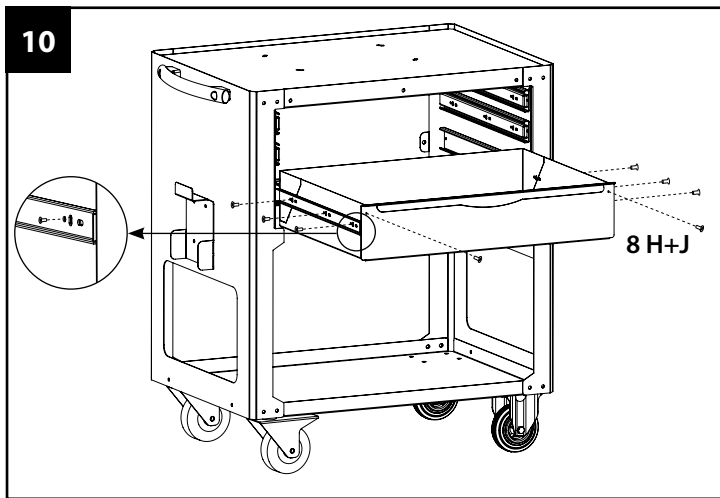
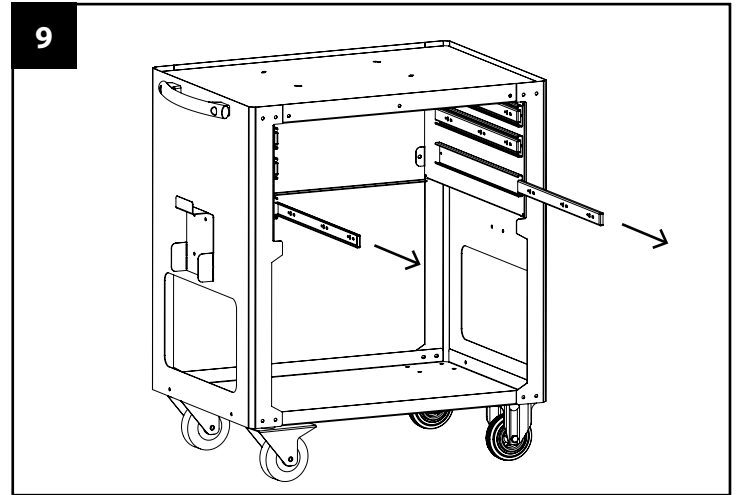
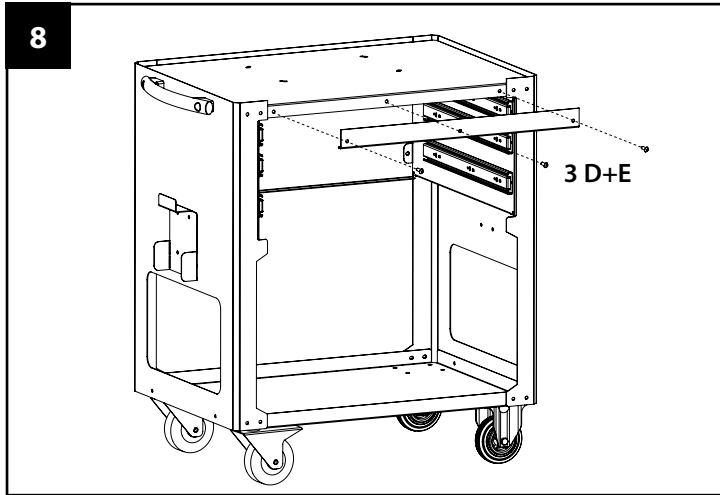



Retirer la face arrière avant de fixer le support riveteuse.  
Pull out the rear panel before attaching the riveting machine support.  
Entfernen Sie die Rückseite, bevor Sie den Träger für das Nietgerät fixieren.

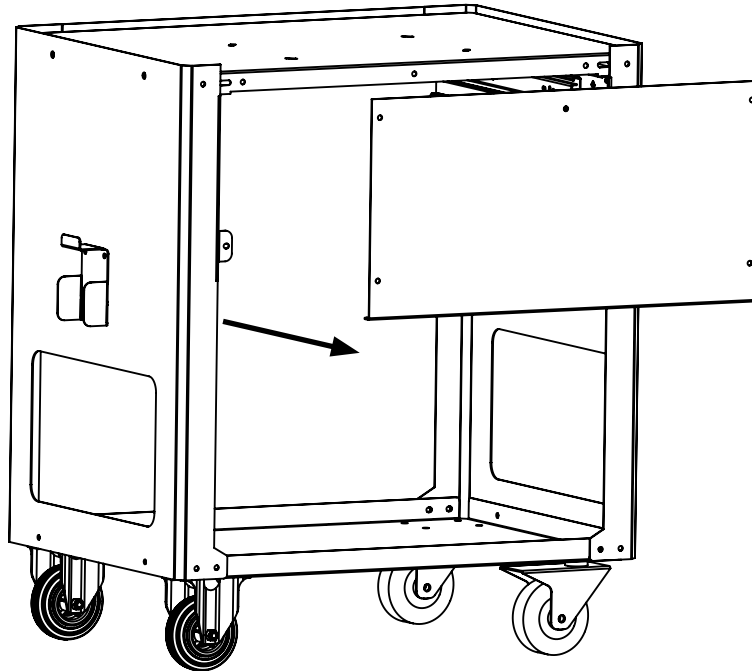

4 D+E

